



VT6B - B09 - 1 R 00 - D 1 02 *

Series

Cam ring

Volumetric displacement cm³/rev (in³/rev)

B02 = 5.8 (0.35)	B08 = 24.9 (1.52)
B03 = 9.8 (0.59)	B09 = 28.0 (1.71)
B04 = 12.8 (0.78)	B10 = 31.8 (1.94)
B05 = 15.9 (0.97)	B11 = 34.9 (2.13)
B06 = 19.8 (1.21)	B12 = 41.0 (2.50)(cont. 175 bar, Max. int 210 bar)
B07 = 22.5 (1.37)	B14 = 45.0 (2.75)(cont. 140 bar, Max. int 175 bar)

Type of Shaft

- 1 - Keyed (Non SAE)
- 2 - Keyed
- 3 - Splined (SAE A)
- 4 - Splined (SAE B)
- 5 - Splined SAE (11 teeth)
- 11 - Splined

Direction of rotation (view on shaft end)

- R - clockwise
- L - counter-clockwise

Porting combination

00 - standard

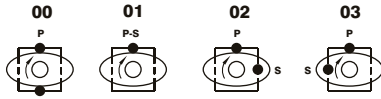

S - Suction port **P** - Pressure port

Modifications

Port connections

CODE	S	P
00	SAE 20 1-5/8" 12 UNF-2B	SAE 12 1-1/16" 12 UNF-2B
01	1-1/4" SAE 4 bolt (UNC)	3/4" SAE 4 bolt (UNC)
M0	1-1/4" SAE 4 bolt (METRIC)	3/4" SAE 4 bolt (METRIC)
02	1-1/4" BSP	3/4" BSP
03	1-1/4" NPTF	SAE 12 1-1/16" 12 UNF-2B
0X	1-1/4" NPTF	3/4" NPTF

Seal class

- 1 - S1 (for mineral oil)
- 4 - S4 (for fire resistant fluids)
- 5 - S5 (for mineral oil and fire resistant fluids)

Design letter

INTERNAL LEAKAGE (TYPICAL)

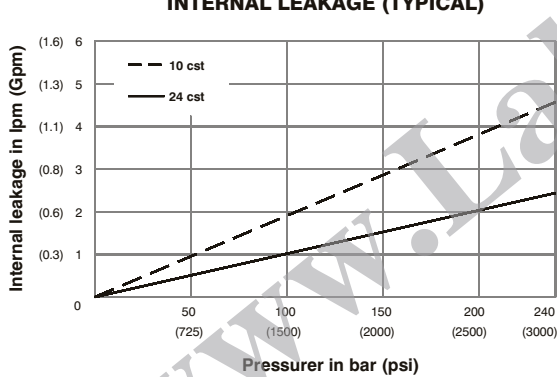

PERMISSIBLE RADIAL LOAD

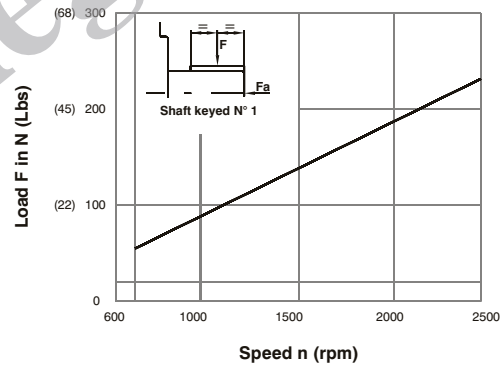

Maximum axial load permissible $F_a = 500$ N (113 Lbs)

OPERATING CHARACTERISTICS (24 cst)

Pressure port	Series	Volumetric Displacement V_p		Flow q & $n = 1500$ rpm						Input power p & $n = 1500$ rpm					
		in ³ /rev	cm ³ /rev	$p = 0$ bar (0 psi)		$p = 140$ bar (2000 psi)		$p = 210$ bar (3000 psi)		$p = 7$ bar (100 psi)		$p = 140$ bar (2000 psi)		$p = 210$ bar (3000 psi)	
				gpm	lpm	gpm	lpm	gpm	lpm	hp	kw	hp	kw	hp	kw
VT6B	B02	0.35	5.8	2.30	8.7	1.4	5.9	--	--	0.53	0.4	2.81	2.1	--	--
	B03	0.59	9.8	3.88	14.7	2.9	11.9	--	--	0.67	0.5	3.62	2.7	--	--
	B04	0.78	12.8	5.08	19.2	4.33	16.4	3.97	15.0	0.93	0.7	5.23	3.9	10.06	7.5
	B05	0.97	15.9	6.31	23.8	5.55	21.0	5.18	19.6	1.00	0.75	6.64	4.9	11.2	8.3
	B06	1.21	19.8	7.85	29.7	7.12	26.9	6.66	25.2	1.07	0.8	8.05	6.0	12.34	9.2
	B07	1.37	22.5	8.92	33.7	8.17	30.9	7.80	29.5	1.20	0.9	9.05	6.7	14.02	10.4
	B08	1.52	24.9	9.89	37.4	9.15	34.6	8.78	33.2	1.34	1.0	10.05	7.5	15.69	11.7
	B09	1.71	28.0	11.11	42.0	10.37	39.2	10.00	37.8	1.47	1.1	11.94	8.9	23.60	17.6
	B10	1.94	31.8	12.61	47.7	11.87	44.9	11.51	43.5	1.6	1.2	13.0	9.7	26.0	19.6
	B11	2.13	34.9	13.85	52.3	13.09	49.5	12.72	48.1	1.7	1.3	14.0	10.5	28.0	21.0
	B12	2.50	41.0	16.27	61.5	15.53	58.7	*	*	1.8	1.4	15.02	11.2	*	*
	B14	2.75	45.0	17.86	67.5	17.12	64.7	**	**	2.1	1.6	15.42	11.5	**	**

- Not to use because internal leakage greater than 50% of theoretical flow.

* B12 = 210 bar (3000 psi) Max.Int

** B14 = 175 bar (2500 psi) Max.Int

SP

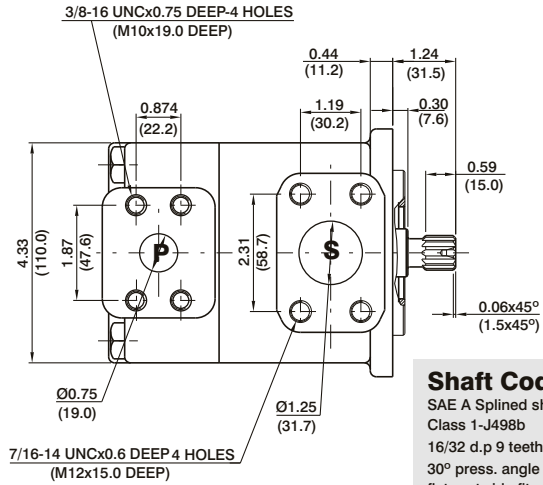

Shaft Code 3
SAE A Splined shaft
Class 1-J498b
16/32 d.p 9 teeth
30° press. angle
flat root side fit

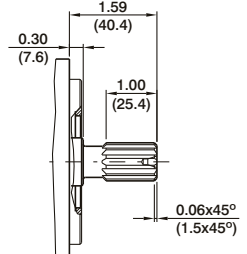

Shaft Code 4
SAE B Splined shaft
Class 1-J498b
16/32 d.p 13 teeth
30° press. angle
flat root side fit

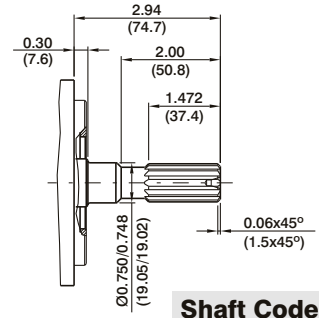

Shaft Code 11
Splined shaft
Class 1-J498b
16/32 d.p 11 teeth
30° press. angle
flat root side fit

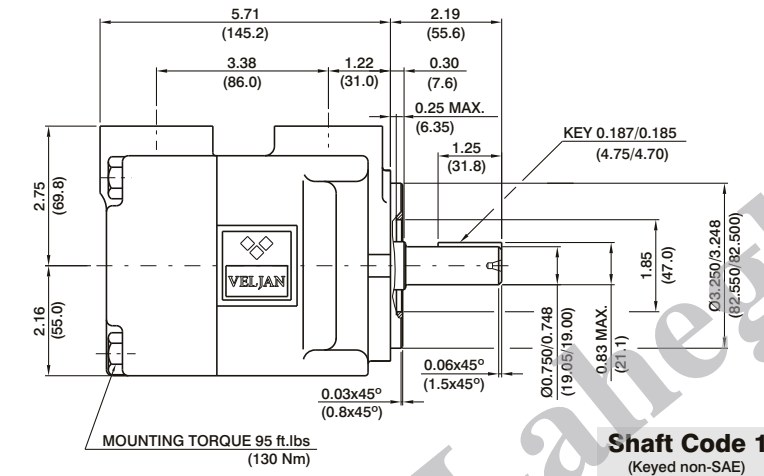

Shaft Code 1
(Keyed non-SAE)

Shaft torque limits in ³ /revxpsi(ml/revxbar)	
Shaft	Vp x p max.
3	5119 (5780)
4	18246 (20600)

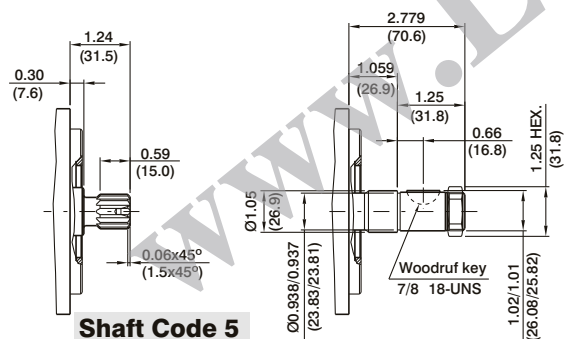
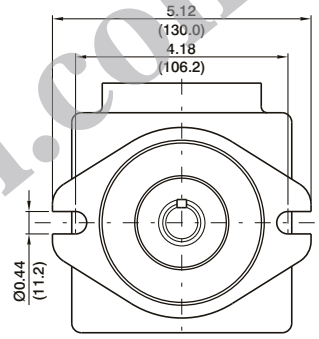

Shaft Code 5
SAE Splined shaft
Class 1-J498b
16/32 d.p 11 teeth
30° press. angle
flat root side fit

Shaft Code 2
Woodruff key
Recommended
nut Torque
125 ft.lbs (170 Nm)

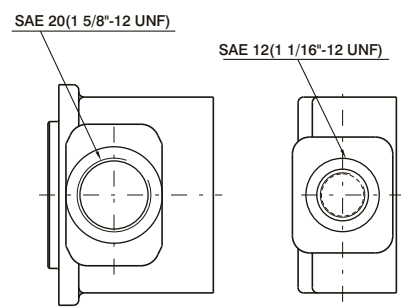

PORT CONNECTION 00

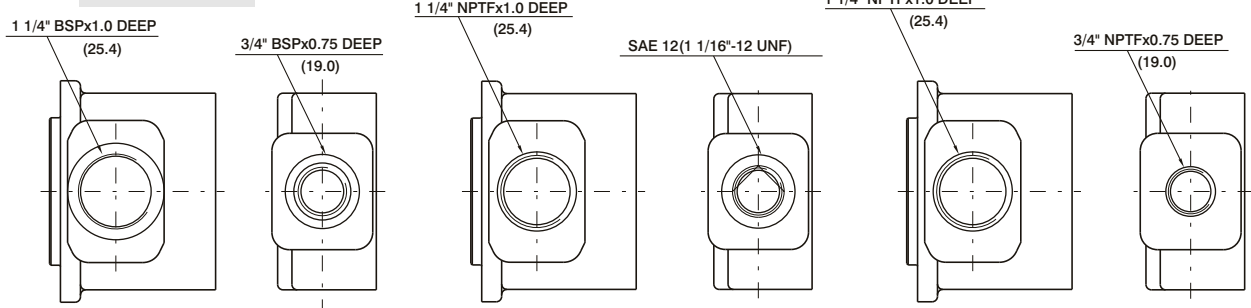

PORT CONNECTION 02

PORT CONNECTION 03

PORT CONNECTION 0X